

WinTens

THE PERFECT WINDER FOR 2END & 3END BCF LINES

- » 2cop winder WinTens602 or 3cop winder WinTens903
- » Including a take-up cradle for the full bobbins - optional available with lift function
- » Individual inverter system installed at the back of the winder to reduce the installation and maintenance time
- » Winder control system offers statistic functions, connection to a doffing system and/or to a main control system via OPC

Version	Denier range* dtex/yarn end	Take-up speed* (in m/min)	Chuck diameter* (in mm)	Max. package diameter* (in mm)	Max. package volume** (in dm ³)	Tube length (in mm)	Stroke (in mm)
WinTens602	300 ... 3,000	1,500 ... 3,000	73	300	16.4	290	250
WinTens903	300 ... 3,000	1,500 ... 3,000	73	300	16.4	290	250

* max. values cannot be combined

** calculated with the smaller chuck diameter

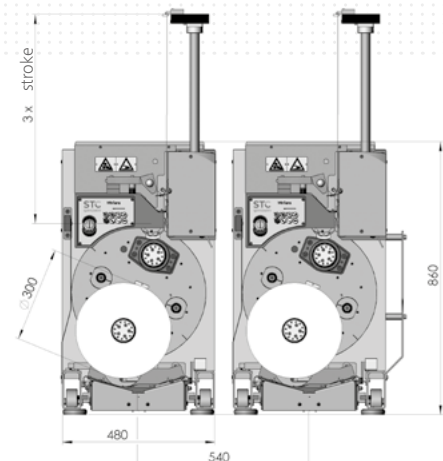
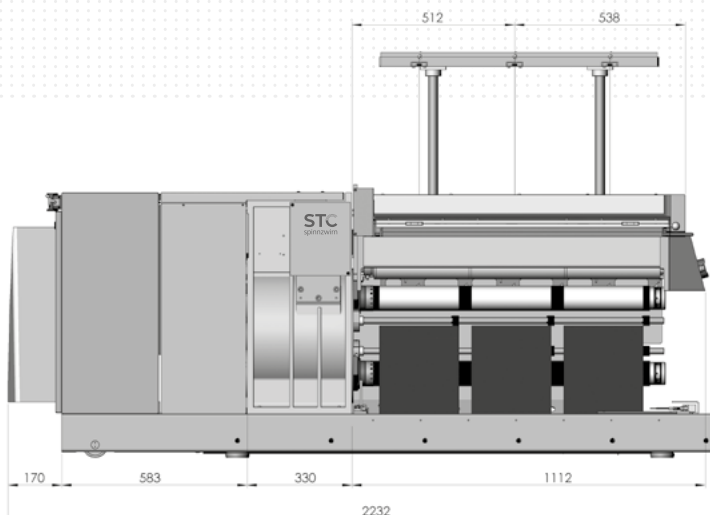



Textile machinery and
equipment from Chemnitz

A member of Starlinger Group

stc-spinnzwirn.com

STC Spinnzwirn GmbH

Zwickauer Straße 247
09116 Chemnitz
Germany
+ 49 371 23 88 / 240
info@stc-spinnzwirn.com
stc-spinnzwirn.com

The information supplied in this
brochure is for guidance only.
We reserve the right to modify
it at any time.

Reprint only with expressed
Permission of STC Spinnzwirn